

REVISIONS				
CHANGE ORDER	LTR	DESCRIPTION	DATE	APPROVED
Q09035	1	ADDED TOLERANCES & PART NO'S	10/06/09	

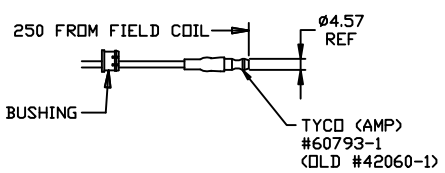

TERMINAL LEAD DETAIL

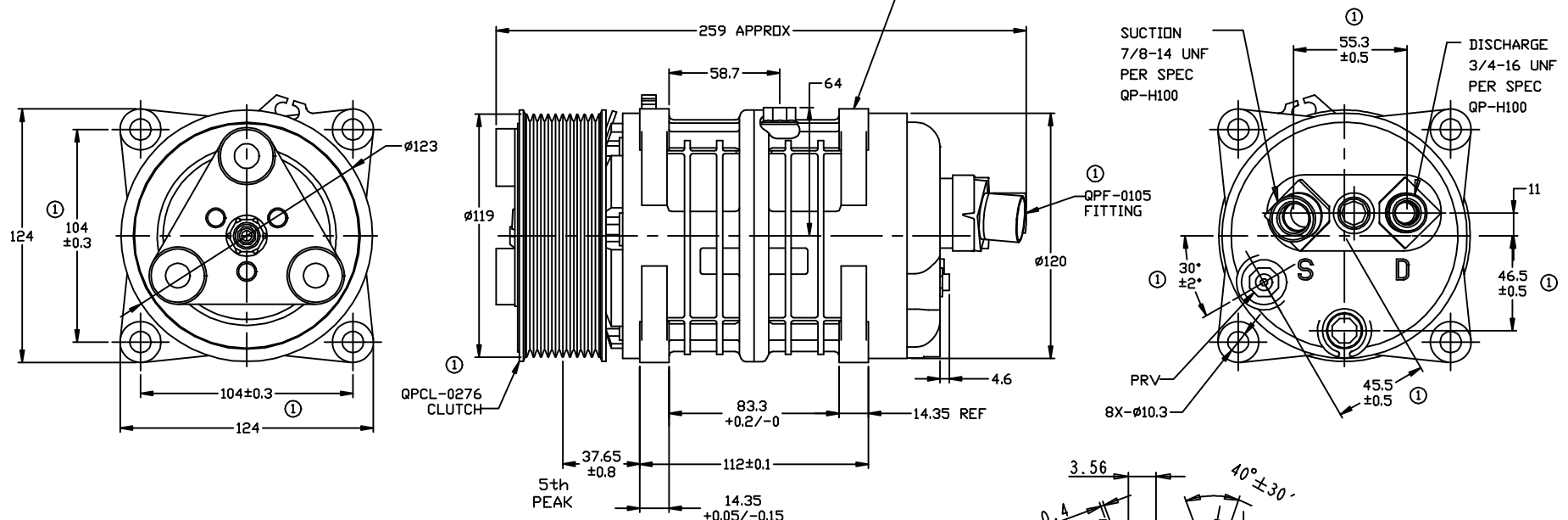

- CLUTCH SPECIFICATIONS:**
- VOLTAGE..... 24VDC
 - BELT..... PV10
 - STATIC TORQUE
 INITIAL..... 35 Nm (3.5 Kgfm)
 AFTER BURNISHING..... 49 Nm (5 Kgfm)
 - MAX POWER CONSUMPTION..... 45W @ 25°C
 - ROTATION DIRECTION..... CW OR CCW
 - WEIGHT..... 2.28 Kg

- COMPRESSOR SPECIFICATIONS:**
- MODEL..... QP16
 - NUMBER OF CYLINDERS..... 6
 - BORE X STROKE..... 36 X 26.7 mm
 - DISPLACEMENT..... 162.9 cm³/REV
 - SPEED RANGE..... 700 - 6000 RPM
 - ROTATION DIRECTION..... CW OR CCW
 - REFRIGERANT..... R-134a
 - LUBRICANT..... PAG 46 180+20cm3
 - WEIGHT..... 4.7 Kg

THIRD ANGLE PROJECTION	UNLESS OTHERWISE SPECIFIED DIMENSIONS ARE IN MM. INTERPRET DIM AND TOL PER ASME Y14.5M - 1994		CAD GENERATED DRAWING. DO NOT MANUALLY UPDATE	
	DRAWN	GLB	DATE	06/24/09
FINISH	CHECKED			
	APPROVED			
	ENG APPVL			

QUE PRODUCTS, LLC
 DECATUR, ILLINOIS

TITLE: **COMPRESSOR ASSEMBLY**
 QP16HD H-3/4-7/8
 PV10 119mm 24V 3-EYE

SIZE A	CODE IDENT NO	DWG NO	REV 1
		QP16-1711	

SCALE NONE SHEET 1 OF 1